

RTB30N

2 Pallet Freezer Body

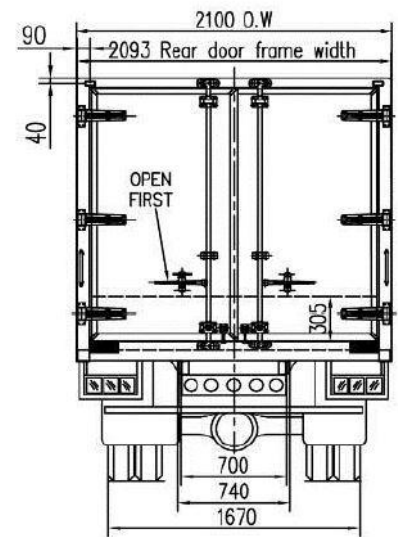
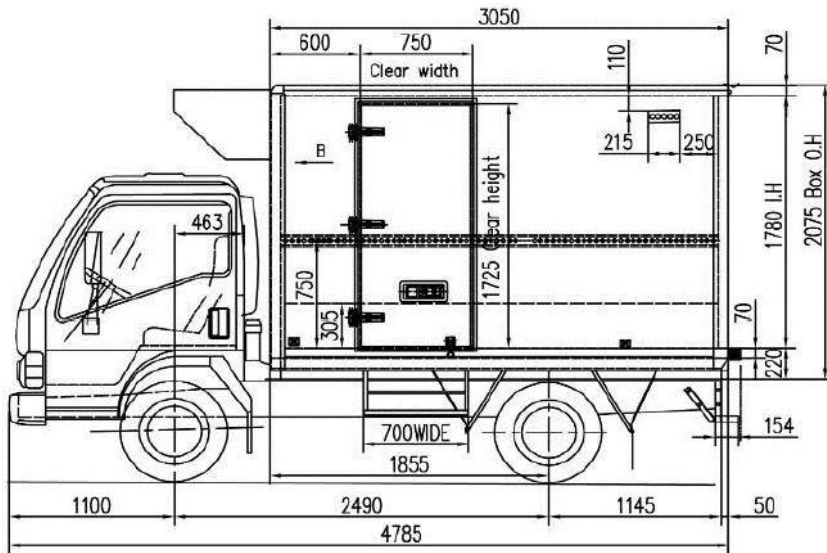

STANDARD FEATURES

- * Thermal breaks on all doors
- * Fiberglass & Polyurethane foam panel with internal ribbing
- * Steel sub-frame
- * LED Interior lights including internal switch
- * Stainless steel hardware
- * Stainless steel rear door frame
- * Emergency exit door opening (rear door only)
- * Rear door gutter

SPECIFICATIONS

Length: External 3050mm Internal 2905mm.

Width: External 2100mm Internal 1944mm.

Height: External 2085mm Internal 1780mm.

Pallet Capacity: 2 Pallet.

Capacity: 10 m³.

Panel Thickness:

- * Roof and Front Wall 70 mm
- * Floor 100 mm
- * Rear 70 mm
- * Side 70 mm

Approx. Body Weight: 895kg.

Temperature Capacity: -20 degrees.

Side Door: Single Passenger side 750 x 1725 mm (Swing to the Left).

Rear Door: 2 Rear Barn doors, Passenger side open first.

Front Wall Frame: Universal to suit diesel and off engine drive units.

Steps: Galvanized side and rear steps.

Cargo Track: 1 @ 750 mm 1 Shoring bar.

Floor: Heavy duty fully welded extruded alum. Floor Inc. 200 mm kick plate.

Features: FurgoCar stainless steel recessed side door locks.